

**6 Attaching the Removeable Panel | Fixer le panneau amovible**

**6.1** Attach the removeable panel to the plastic clips. |  
Fixer le panneau amovible aux clips en plastique.

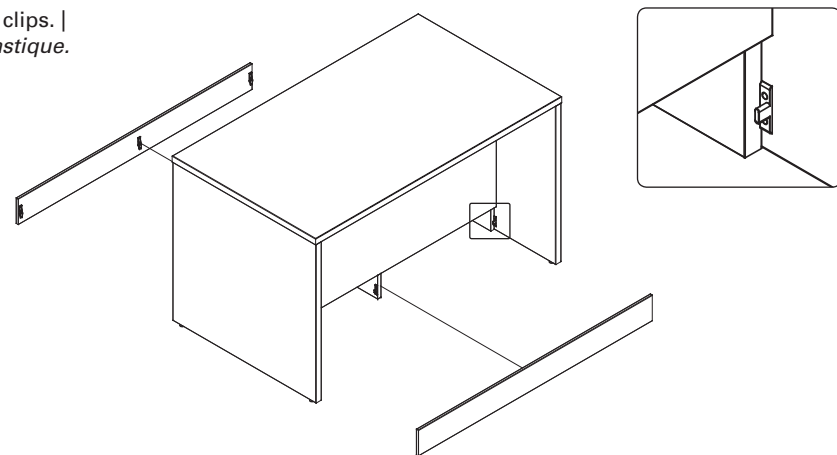

**Link**

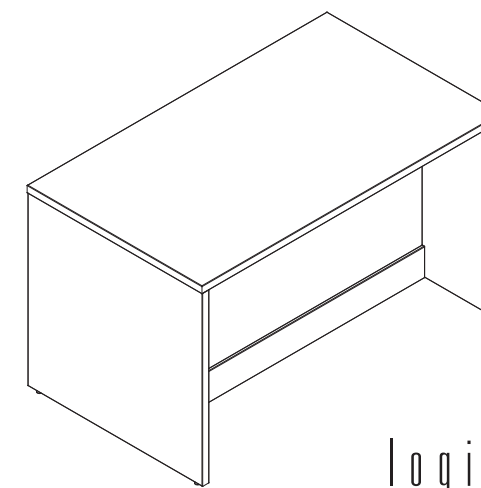

**Assembly Instructions  
Instructions d'assemblage**

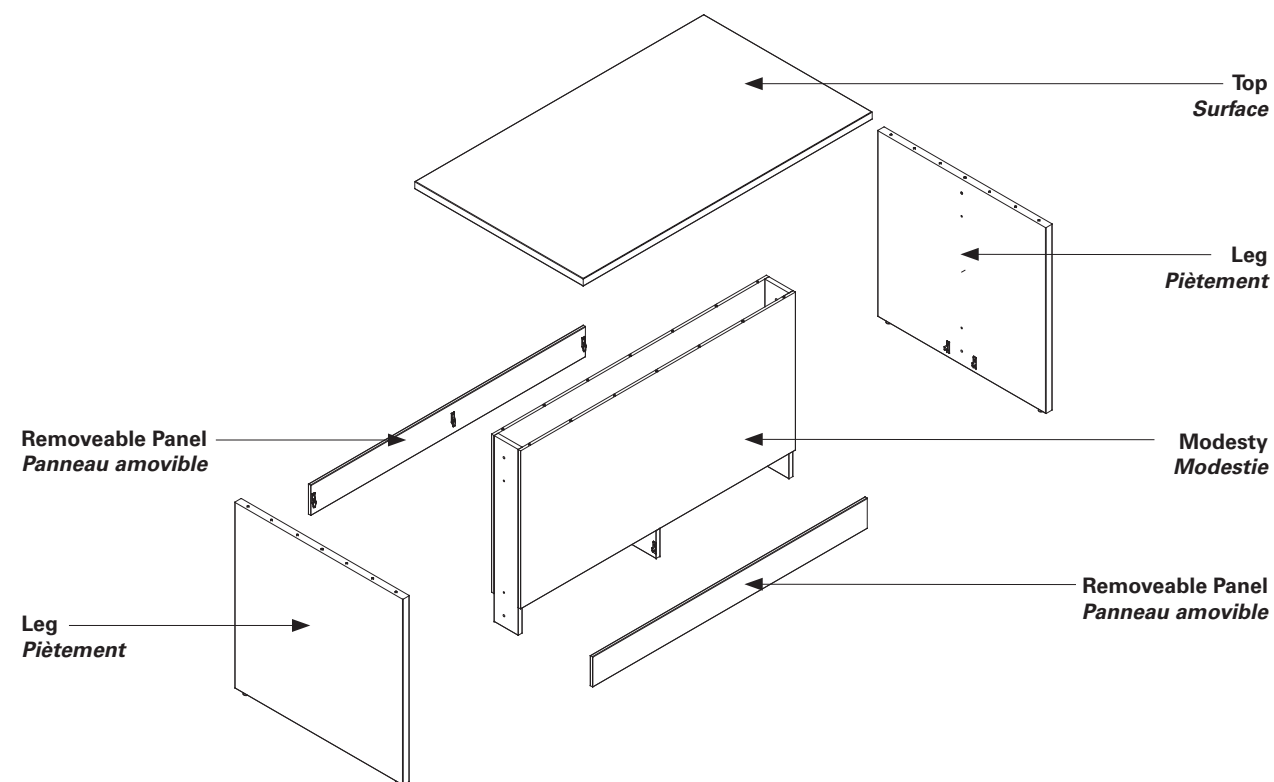

**Components | Pièces**

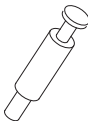

**Hardware | Quincaillerie**

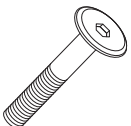
Pin Cam	Cam	Wood Dowel Goujon de bois	Screw   Vis 30mm, 1/4" - 20
			
16x	16x	16x	4x

As our product line is constantly evolving and expanding, we recommend that you visit [logiflex.ca](http://logiflex.ca) for updates.  
En raison de l'évolution constante des lignes de produits, Logiflex vous encourage à consulter les mises à jour au [logiflex.ca](http://logiflex.ca).

**logiflex**

1235 St-Roch N., Sherbrooke QC J1N 0H2 Canada  
T : 1.877.864.9323 | F : 1.800.474.7830 | [logiflex.ca](http://logiflex.ca)



Printed in Canada | November 2016

**1 Attaching the Legs to the Modesty | Assembler les piétements avec le modestie**

1.1 Attach the laminate legs to the modesty unit with the dowels. | *Assembler les piétements de mélamine avec modestie à l'aide des goujons.*

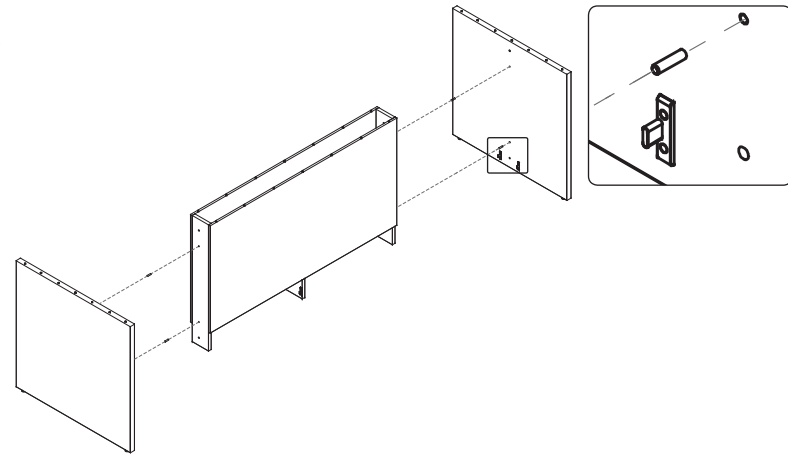

**2 Securing the Legs to the Modesty | Fixer les piétements au modestie**

2.1 From inside the modesty section, secure the legs to the base using the supplied screws. | *De l'intérieur du modestie, fixer les piétements à la base en utilisant les vis fournies.*

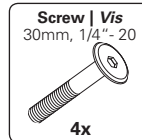
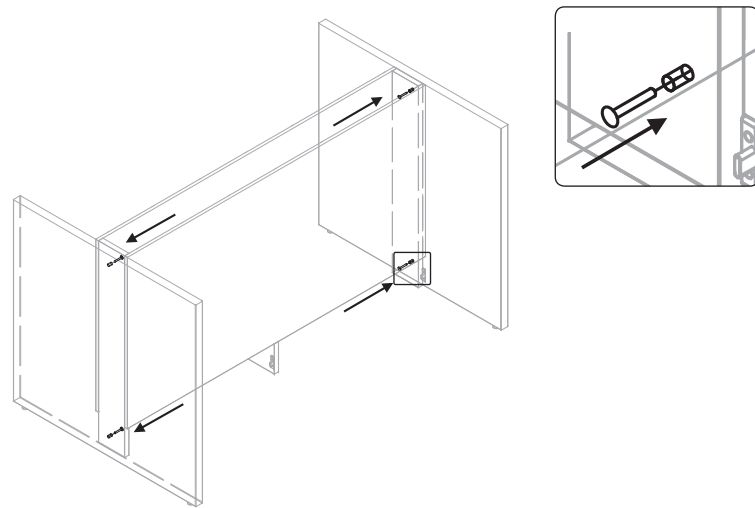

**3 Preparing the Base | Préparer la base**

3.1 Prepare the base unit to receive the surface by inserting the wooden dowels and cams. | *Préparer la base à recevoir la surface en insérant les goujons de bois et les Cam.*

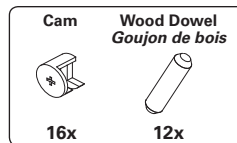
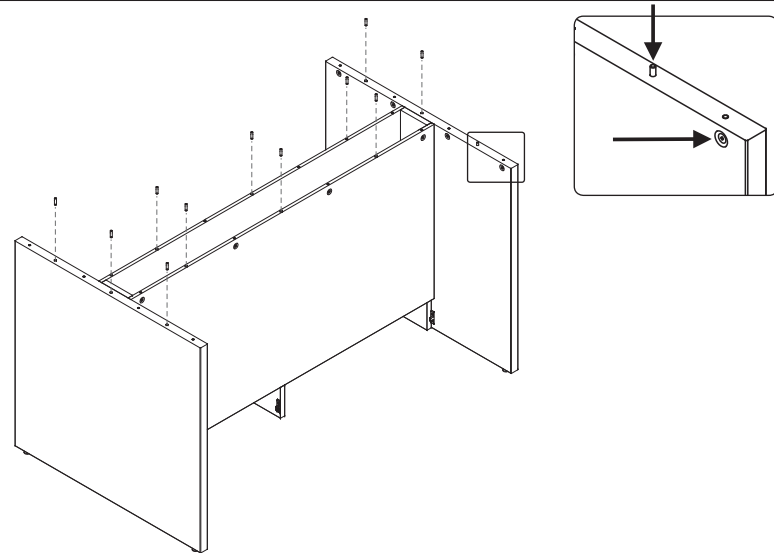

**4 Preparing the surface | Préparer la surface**

4.1 Prepare the surface by screwing the Pin Cams to the underside of the surface. | *Préparer la surface en vissant les Pin Cam sous la surface.*

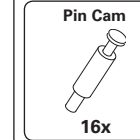
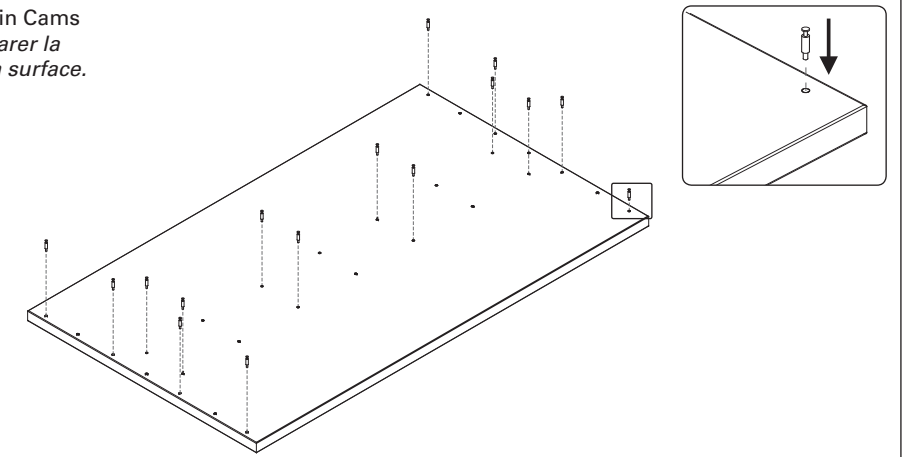

**5 Assembling the Surface | Assembler la surface**

5.1 Place the surface into position. | *Placer la surface sur les piétements.*  
5.2 Tighten cams. | *Visser les Cam.*

